

# For Lease

510 Trans-Canada Highway, AB-1 | Strathmore, AB

**Undergoing a Complete Façade Renovation and Update — JANUARY 2025 COMPLETION!**



## Demographics 3KM



NEIGHBORHOOD  
Strathmore



POPULATION  
15,080



MEDIAN AGE  
40



HOUSEHOLD INCOME  
\$109,984

## Building Details



PARKING  
Ample Parking



YEAR BUILT  
2000



TRAFFIC COUNT  
14,650 VPD | Highway 1



Unit A210, 9705 Horton Road SW,  
Calgary, Alberta, T2V 2X5  
P (403) 214-2344

[blackstonecommercial.com](http://blackstonecommercial.com)

# Country Plaza

## Property Details

<b>Size Available:</b>	<b>Unit A1</b> - 956 SF <b>Unit F</b> - 925 SF <b>Unit H</b> - 1,820 SF
------------------------	---

<b>Availability:</b>	Negotiable
----------------------	------------

<b>Net Rate:</b>	Contact Associate
------------------	-------------------

<b>Op Costs:</b>	\$7.50 PSF
------------------	------------

<b>Zoning:</b>	C-SC
----------------	------

## Highlights

- Single storey retail development located on major intersection in Strathmore, with easy access and great exposure to Highway 1
- Nearby Medical Centres
- PAD Site CRU with drive-thru options

# Site Plan



## Updates to Include

- Full Exterior Façade
- **NEW** Signage
- **NEW** Pylon Sign & Monument sign
- **NEW** Paint + Updated & Enhanced Lighting
- **NEW** Tenant Signage

W H E A T L A N D T R A I L



## Elevation



# Floor Plans

**Unit H**  
1,820 SF

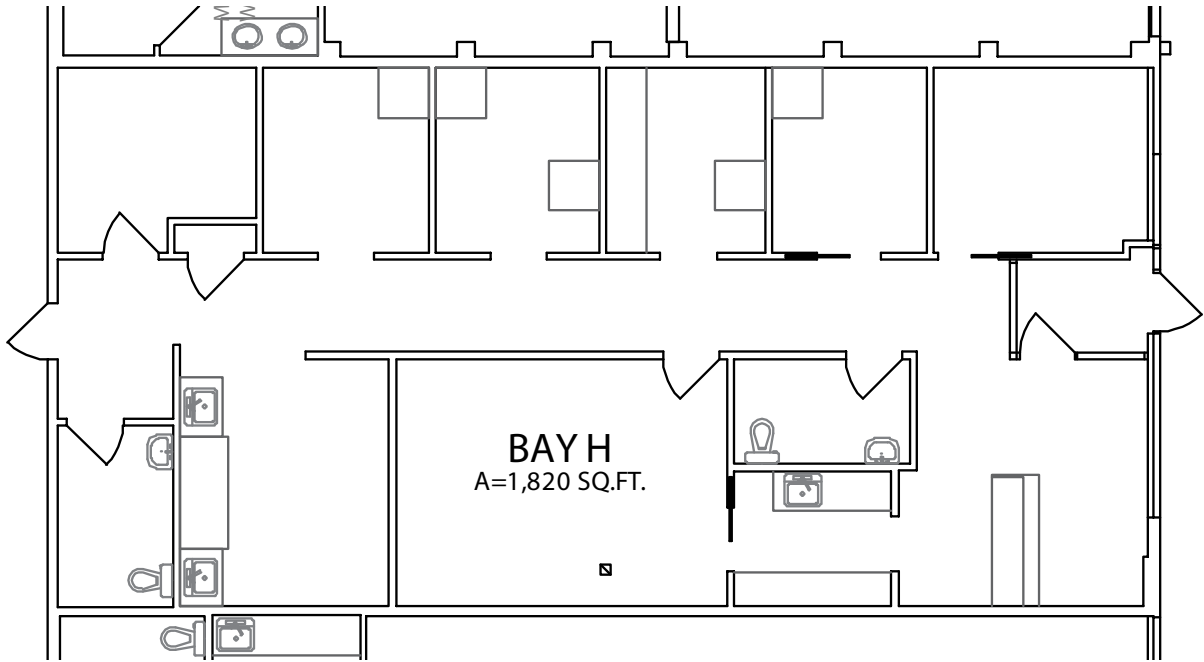

**Unit F**  
925 SF

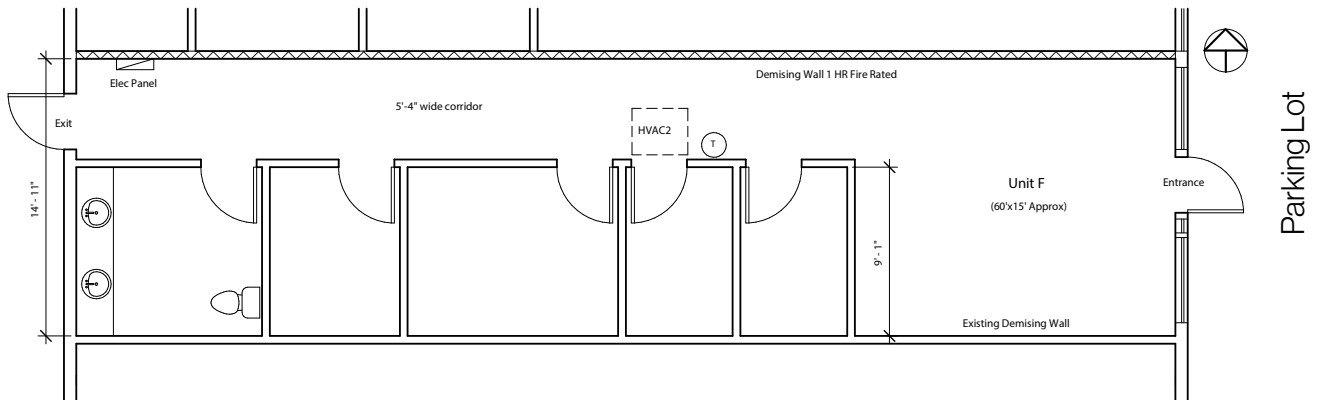

**Unit A1**  
956 SF

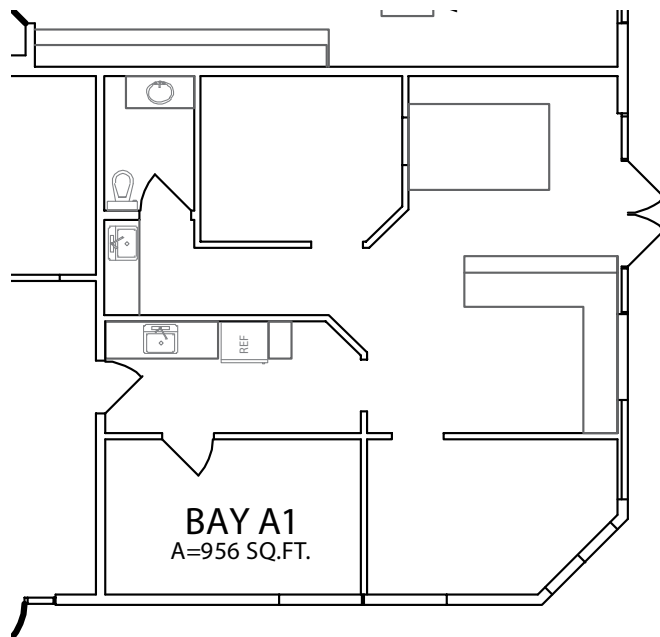

- 1 Strathmore District Health Services
- 2 Wheatland & District Ambulance
- 3 Strathaven Court
- 4 Strathmore Ag Grounds
- 5 Strathmore Provincial Court
- 6 Westmount School
- 7 Royal Canadian Mounted Police (RCMP)

 **View in**



# Thank you for your Interest!

## For More Info.

**Mahmud Rahman**

**P** 403.930.8651

**E** mrahman@blackstonecommercial.com

**Randy Wiens**

**P** 403.930.8649

**E** rwiens@blackstonecommercial.com

This document has been prepared by Blackstone Commercial for advertising and general information only. Although information has been obtained from sources deemed reliable, Blackstone Commercial and / or their representatives, brokers or agents make no guarantees, representations or warranties of any kind, expressed or implied, regarding the information including, but not limited to, warranties of content, accuracy and reliability. Blackstone Commercial excludes unequivocally all inferred or implied terms, conditions and warranties arising out of this document and excludes all liability for loss and damages arising therefrom. © 2024, All rights reserved. This document is the copyrighted property of Blackstone Commercial.

[blackstonecommercial.com](https://blackstonecommercial.com)

Follow us:  
Blackstone  
Commercial



 **Blackstone**  
Commercial Real Estate Services