

# For Lease

Highway 12 & Highway 2 | Lacombe, AB



## Demographics



NEIGHBORHOOD  
Lacombe



POPULATION  
14,229



MEDIAN AGE  
38



HOUSEHOLD INCOME  
\$124,254

## Building Details



PARKING  
Ample



YEAR BUILT  
2019 - 2021



TRAFFIC COUNT  
29,540 VPD | Hwy 12 & Hwy 2  
21,610 VPD | Hwy 12 & 76 St.



Unit A210, 9705 Horton Road SW,  
Calgary, Alberta, T2V 2X5  
P (403) 214-2344  
blackstonecommercial.com

## Midway Centre

### Property Details

Lot 1	1 - Future Development
Lot 1B	Building A <b>FULLY LEASED</b> Building B 6,300 SF
Lot 2	Building A 2,500 SF Building B <b>FULLY LEASED</b> Building C 10,000 SF
Lot 3	Building A 5,800 SF Building B 2,800 SF Building C 9,942 SF

### Size Available:

Net Rate: Market

Op Costs: \$6.00 PSF

### Highlights

- One of the largest commercial development opportunities in the area
- Ideal location for retail, entertainment, restaurants or pub, outlets stores, oil changer or car wash
- Midway Centre will be a commercial hub for Southern Alberta, and a destination for travelers on the major highways
- 3.8 acre multi-family development located on west side of the City of Lacombe, and over 60 acres commercial development
- Negotiations with multiple national big-box retailers as anchors are underway
- Units can be demised or combined

# Site Plan

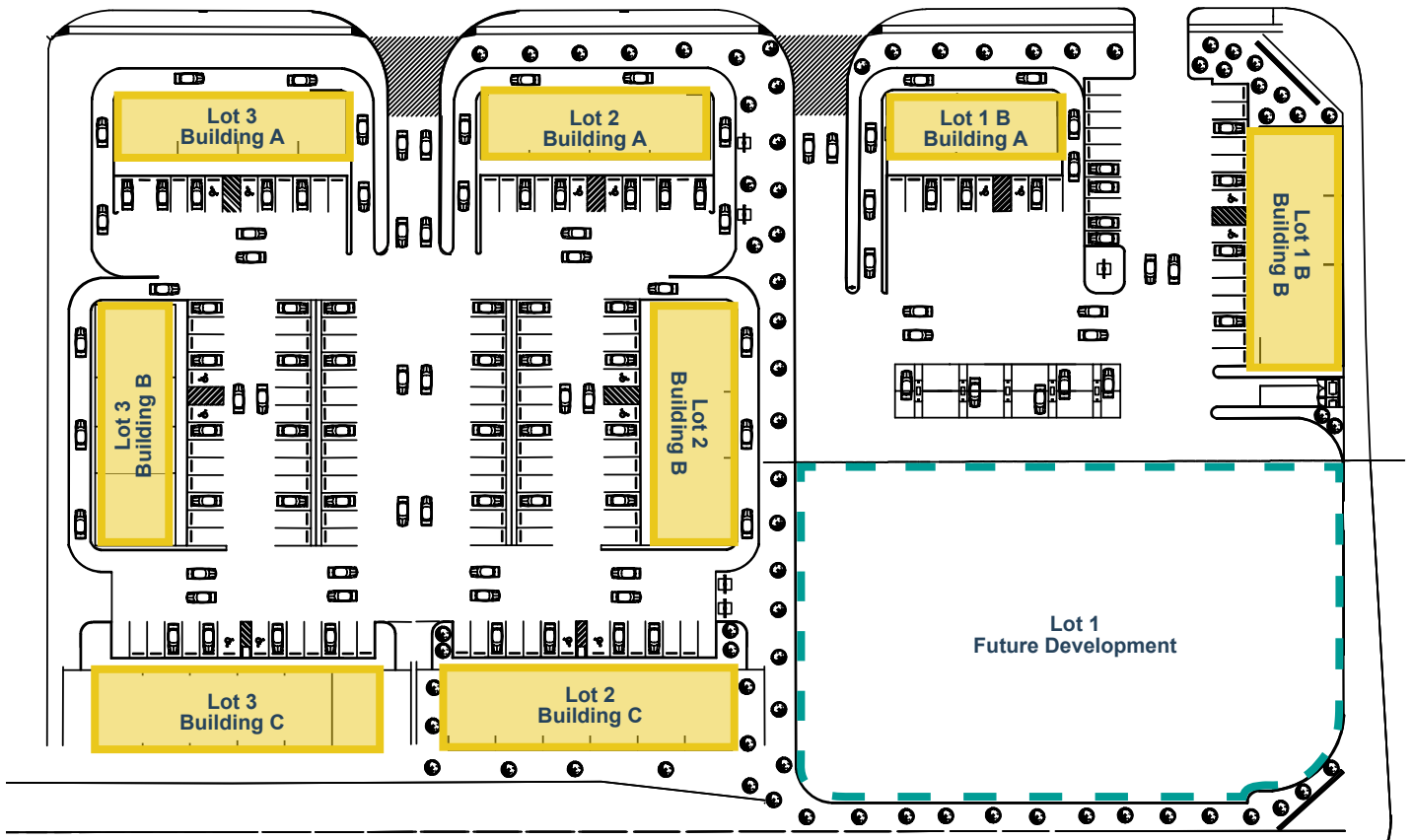
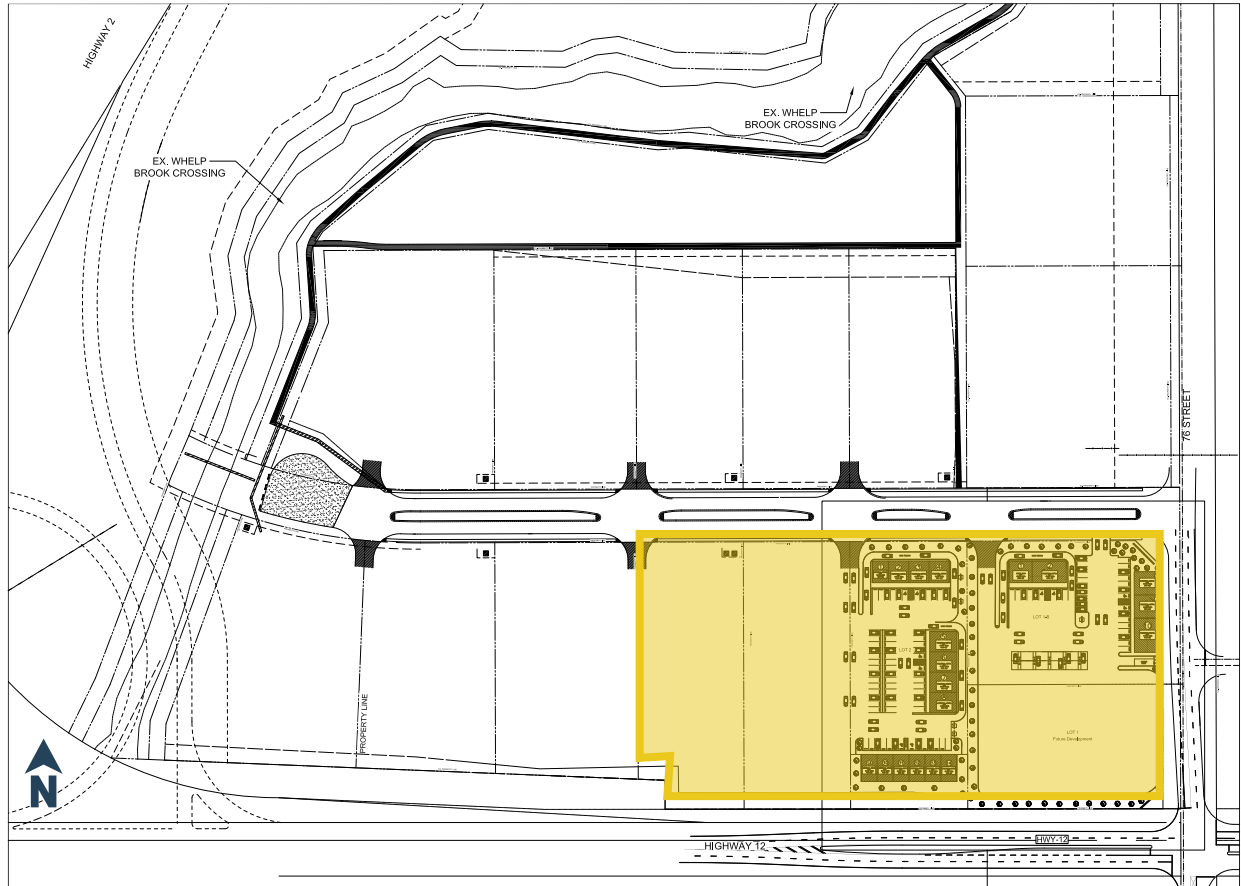

# Leasable Area

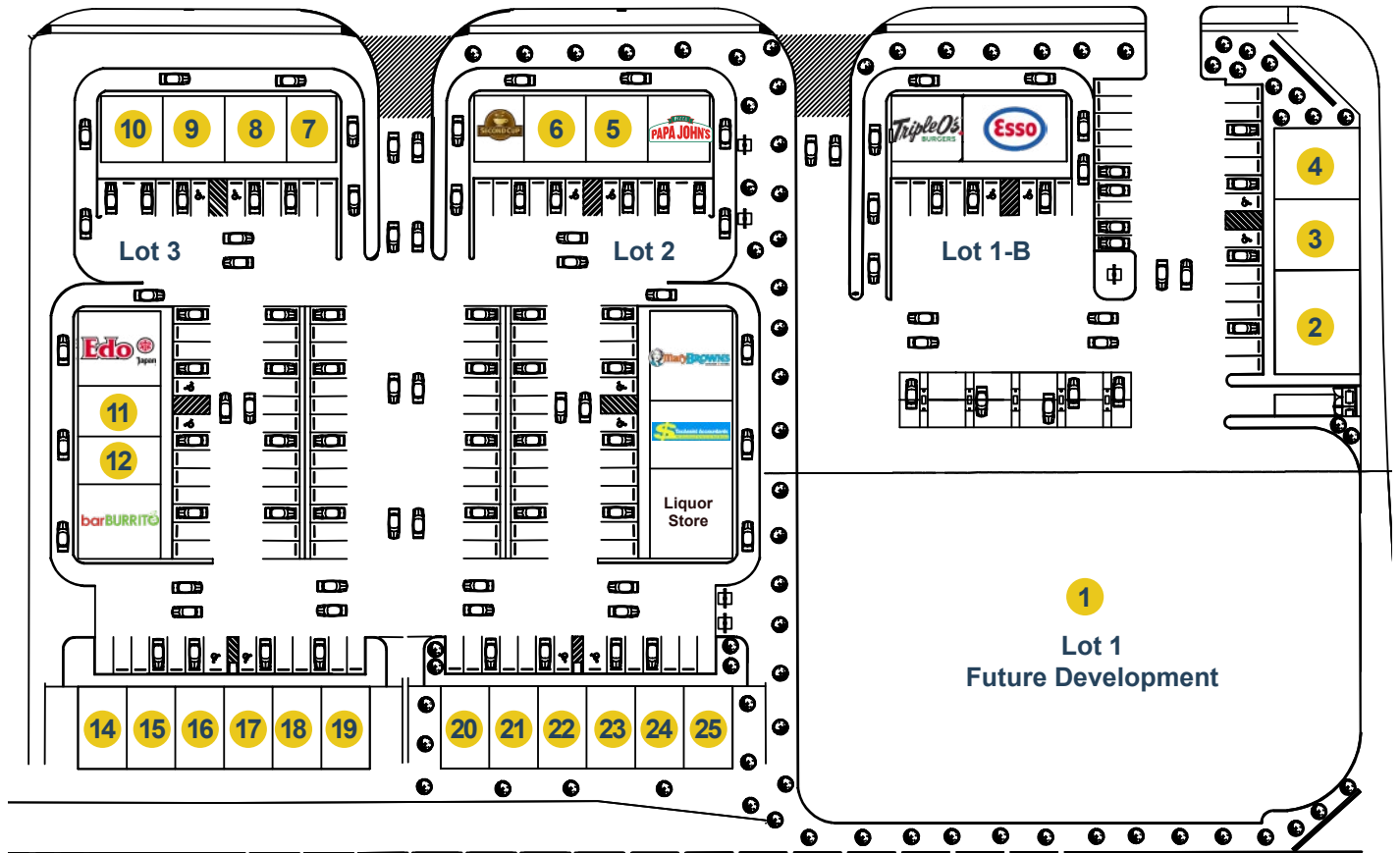

For Example Only

**Blackstone**

## Lots 1, 2 & 3

### Lot 1

- Future Development

### Lot 1B

- Unit 2 - 2,100 SF
- Unit 3 - 2,100 SF
- Unit 4 - 2,100 SF

\*Pad opportunity available

### Lot 2 Building A

- Unit 5 - 1,250 SF
- Unit 6 - 1,250 SF

### Lot 2 Building C

- Unit 20 - 1,433 SF
- Unit 21 - 1,433 SF
- Unit 22 - 1,433 SF
- Unit 23 - 1,433 SF
- Unit 24 - 1,433 SF
- Unit 25 - 1,433 SF

### Lot 3 Building A (+2 Spaces)

- Unit 7 - 1,453 SF
- Unit 8 - 1,453 SF
- Unit 9 - 1,453 SF
- Unit 10 - 1,453 SF

### Lot 3 Building B

- Unit 11 - 1,400 SF
- Unit 12 - 1,400 SF

### Lot 3 Building C

- Unit 14 - 1,657 SF
- Unit 15 - 1,657 SF
- Unit 16 - 1,657 SF
- Unit 17 - 1,657 SF
- Unit 18 - 1,657 SF
- Unit 19 - 1,657 SF

For Lease

Highway 12 & Highway 2 | Lacombe, AB



Blackstone

[www.BlackstoneCommercial.com](http://www.BlackstoneCommercial.com)



# Thank you for your interest!

For More Info.

**Patrick White**

P (403) 214-2344 Ext.2346

E [pwhite@blackstonecommercial.com](mailto:pwhite@blackstonecommercial.com)

Unit A210, 9705 Horton Road SW, Calgary, Alberta T2V 2X5 | P (403) 214-2344

This document has been prepared by Blackstone Commercial for advertising and general information only. Although information has been obtained from sources deemed reliable, Blackstone Commercial and / or their representatives, brokers or agents make no guarantees, representations or warranties of any kind, expressed or implied, regarding the information including, but not limited to, warranties of content, accuracy and reliability. Blackstone Commercial excludes unequivocally all inferred or implied terms, conditions and warranties arising out of this document and excludes all liability for loss and damages arising therefrom. © 2022, All rights reserved. This document is the copyrighted property of Blackstone Commercial.

[blackstonecommercial.com](http://blackstonecommercial.com)

 **Blackstone**  
Commercial Real Estate Services